

Supplemental Notes:

The Architecture of Man

If God really “indwells” us, why do we behave the way we do?

Tape 1: System Architecture

Insights from computer system design.

Tape 2: Temple Architecture

Seven times the New Testament points us to Solomon’s Temple as the key to understanding ourselves.

© 1994 Koinonia House Inc.

The Architecture of Man

The Great Commandment

Matthew 22:37 (vs. Deuteronomy 6:4,5).

Agapao: Is “Agapao” Divine Love? [of Luke 11:43; John 3:19; 12:43, etc.]

Heart? Jeremiah 17:9

Soul? Hebrews 4:12

Mind? The Greek word here is *dianoia*, “channel,” or “will power.” (The Greek word for mind is *nous*, which means a whole process that includes not only the conceptions of an idea, but also its fulfillment.)

System Architecture

Computer Hardware Organization

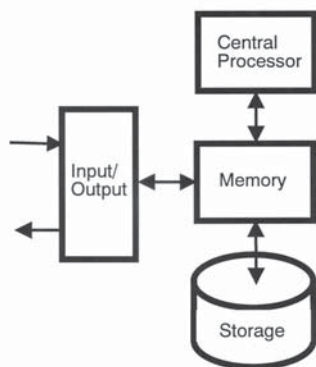

Page 2

The good news is that unless you are designing or building them, you don't need to know any of this stuff! In fact, *you can't understand the behavior of a computer by complete knowledge of circuits and hardware!*

Can you understand its *behavior* by x-rays of hardware? Or by studying the complete wiring diagrams? Hardly. The Von Neuman architecture involves *self-modifying programs*. It is an “infinite state machine.” To understand the *architecture* of the system requires knowing the design of the *software*.

Computer Software Development

(See chart on page 4.)

Machine Language: rigorous; error prone; expensive.

Assemblers: Manages memory allocation; streamlines tasks; results in lowered costs, improved performance.

Compilers: “Automatic Programming” through problem-oriented languages; machine-independent **Source Code** produces efficient **Object Code** that executes on the “information engine.” Examples: ALGOL, FORTRAN, COBOL, BASIC, LISP, PASCAL, etc.

Key Insight: *you cannot go from “object code” to “source code”* since that requires knowledge of intent.

Software Architecture

(See chart on page 5.)

Page 3

Software Process

Conceptual Environment

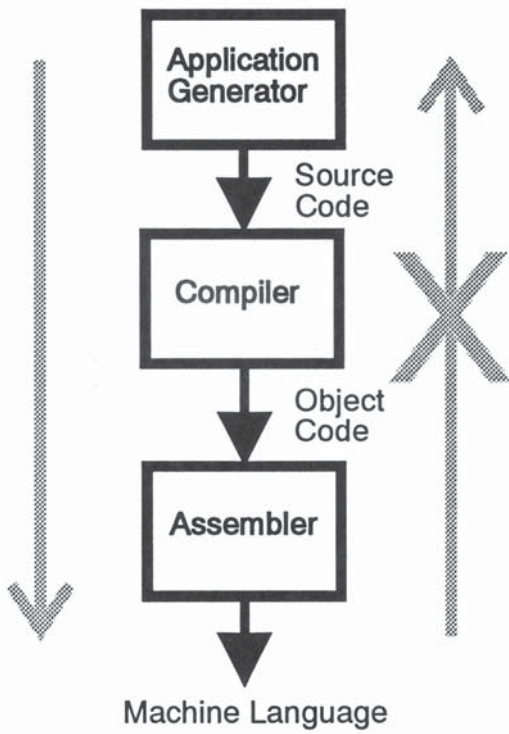

Software Architecture

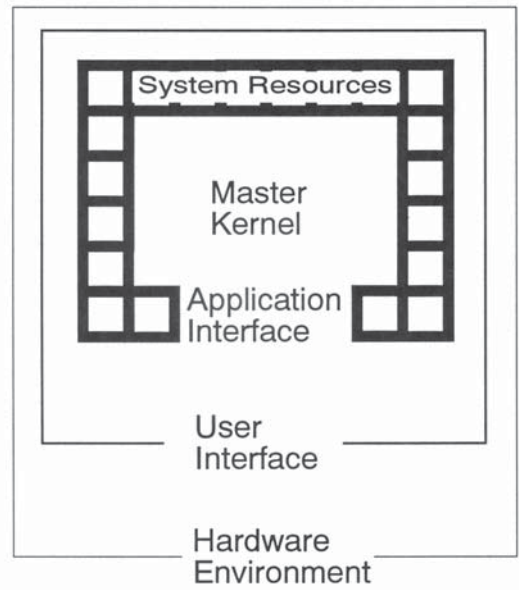

Master Kernel contains analysis algorithms, proprietary techniques, etc. It draws upon a library of **System Resources**: file management systems, sorting programs, graphic processing, etc. This is all embedded in the **Applications Interface**, yielding an external style appropriate to the intended application, such as word processors (WordPerfect, WordStar, Microsoft Word, etc.) and spreadsheet programs (Lotus, Excel, etc.).

All of this is then embedded in the **User Interface** (an Operating System), such as the Graphic User Interface familiar to Macintosh users, of Windows users; or DOS UNIX, etc.

This is all them embedded in the **Hardware Environment**: MAC, PC, etc.

Key Insight: *You cannot infer the internal organization working only from the external shells.*

The Physics of Software

Software has no mass. Its *embodiment* does. A blank diskette weighs about 0.7 ounces. You can load it with over a million bytes of software, costing hundreds of dollars, and it will still weigh only 0.7 ounces.

It can even travel weightless over airwaves.

The Geometry of Eternity

Let's rid ourselves of some misconceptions.

Time is neither linear nor absolute; it is a *physical* property. We now recognize, thanks to Dr. Einstein's General Theory of Relativity, that we exist in a four-dimensional continuum known as

space-time (cf. Ephesians 3:18). Time varies with mass, acceleration, and gravity.

A time measurement device in a weaker gravitational field runs faster than one in a stronger field.

Near the surface of the Earth the frequency increases about one part in 10^{16} per meter. A clock 100 meters higher than a second clock will have a frequency higher by one part in 10^{14} .

Clocks carried eastward around the world on an airplane will differ from a clock at rest on the Earth or one carried westward, since they are in rotation at different speeds about the center of the Earth and there is a difference in gravitational potential.

In 1971, in experiments with atomic clocks by the U.S. Naval Observatory, an eastward flying clock lost 0.06 microsecond while a westward one gained 0.27 microsecond, confirming the predicted relativistic effects.

The "dilation" of time can also be dramatized by considering two hypothetical twin astronauts. One remains on the Earth; the other undertakes a space mission in which the vehicle attains a speed of half the velocity of light, enroute to Alpha Centari and back (about four light years away.) When our traveler returns to the Earth, he will be a little more than two years *younger* than his twin brother.

These examples highlight the fact that time, itself, is a *physical* property of our material world.

There is part of *you* that is not physical. Since that part of you has no mass, it has no time dimension. It is eternal. That's the problem.

The eternal part of you will exist *forever*—either in the presence of God, or forever separated from God.

It is the nature of God to banish sin from His presence. Sin is the inescapable barrier to fellowship with Him. Unless that is dealt with, the second destiny is the result.

Fortunately, our genetic imperfections—inherited from Adam—have been dealt with by a love story. A love story written in blood, on a wooden cross, almost 2,000 years ago. Taking our place, Jesus substituted His eligibility for our own and that eligibility is available for the asking.

The Architecture of the Temple

One of the things that we learn from these software insights is that it is futile to attempt to infer our architecture from a neural analysis, or exploring the physical aspects of the brain, etc. Our soul, our “heart,” etc., simply does not show up on an x-ray or an MRI scan. (It is strange that we should cling the perceptions of a paranoid schizophrenic who lived in Vienna in our attempt to understand our system design.)

Let’s try to understand our “system design” as our System Architect has provided it to us (cf. Heb 4:12). With similitudes and analogies (Hosea 12:10).

“Ye are the Temple of God” appears seven times in the New Testament:

- 1) 1 Cor 3:9-16
- 2) 1 Cor 6:19
- 3) 2 Cor 6:16
- 4) Eph 2:20, 21

- 5) Heb 3:6
- 6) 1 Pet 2:5
- 7) 1 Pet 4:17

(Jesus also refers to His own Body as a Temple: Mark 14:58, John 2:19 etc.)

The Uniqueness of Solomon’s Temple

(See charts on pages 10-11.)

- 1) It was the only Temple where all the detailed plans, not only of the construction of the Temple, but also of all the furniture, were given by the **Spirit of God** (1 Chr 28:12,19).
- 2) It was also the only Temple in which God’s **Spirit dwelt** until the Temple was destroyed. (1 Kgs 8:1-11; 9:3. It finally leaves Ezek 11:23.)
- 3) And it was also the only Temple where the **Ark of the Covenant** dwelt.

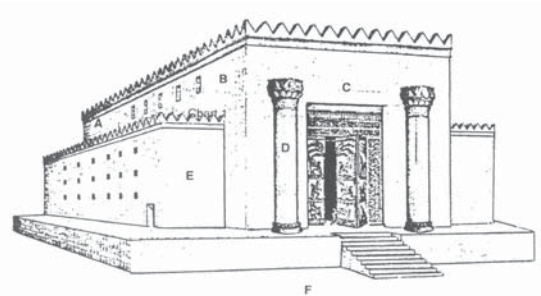

The Temple of God

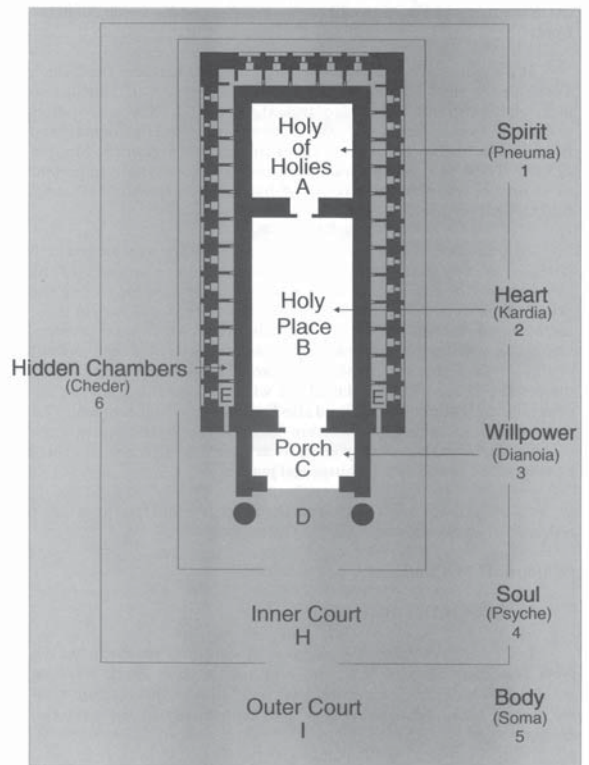
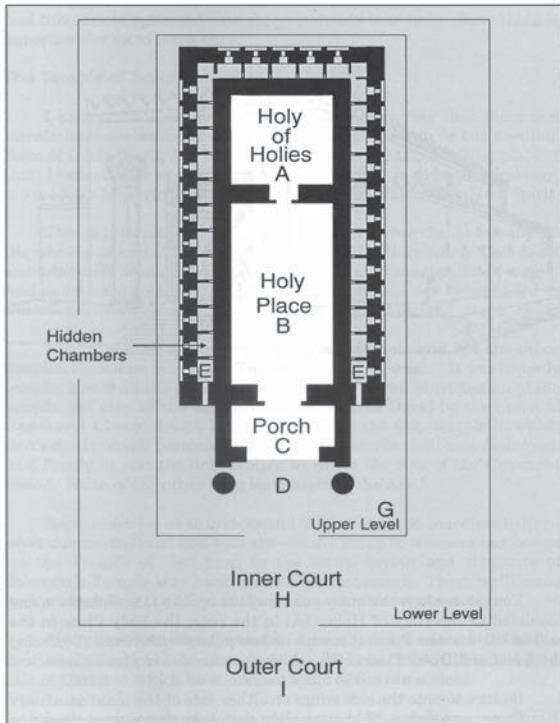

The Shekinah Glory used to dwell in the physical Temple of Solomon in Jerusalem. But God's Spirit now dwells in "temples made without hands" (Acts 17:24).

New Testament Believer

(See chart on page 13.)

Inside the Temple, the Holy of Holies (which corresponds to our new Spirit), the Holy Place (which is our new Heart), and the Porch (which is our new Will Power) are all solid gold. All the furniture and even the walls were of gold. Gold speaks of holiness, deity, and purity.

The pillars of the Temple and all of the items in the Inner and Outer Courts—the lavers, the altar of sacrifice, the "molten sea," etc.—were bronze. Bronze spoke of fire and that which still must be judged, something that is not redeemed yet.

The Hidden Chambers were of wood. (The Hebrew word actually means something "to be burned up.") Here the priests hid their personal idols, thinking they were secret (Ezek 8:6-12). These secret hidden chambers are suggestive of what we sometimes call the "subconscious."

Pneuma (Spirit)

This whole message does not apply, unless you have the Spirit of God in you (1 Peter 1:3,23; John 3:3; 1 Cor 6:17).

Kardia (Heart)

Our old heart is "incurably" wicked: Jer 17:9; Mk 7:21; Rom 3:11-12; A new heart is required: Ps

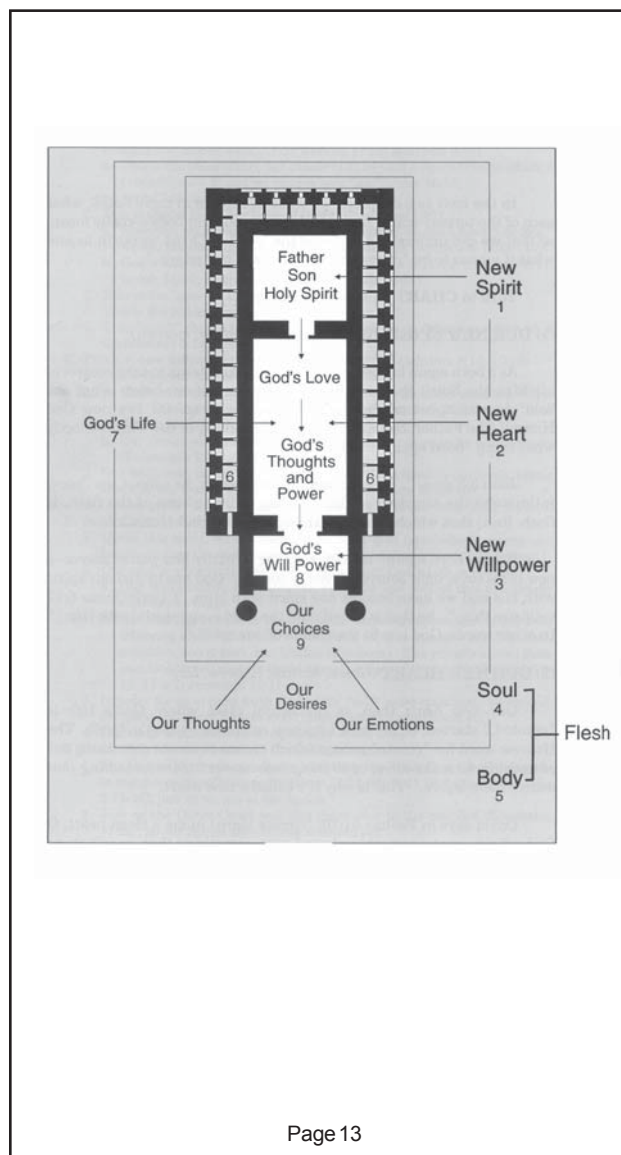

51:10; Ezek 36:26-27; 11:19. It is filled with His supernatural Love (Rom 5:5); His supernatural Thoughts (Heb 8:10). It is a new creation (2 Cor 5:17). It is then God's Life in our hearts and not our own (Eccl 3:11; Eph 4:24); "new wineskins" (Luke 5:37, Mark 2:21 and Matthew 9:17); "being circumcised" (Col 2:11; Phil 3:3; Gal 6:15).

Dianoia ("Channel") Will Power

Our new will power is given at our new birth (Heb 8:10, 10:16). Our will power is the passageway, doorway or gateway from our hearts into our lives. The bronze pillars associated with the porch were named: The right pillar was called Jachin, which meant "in His Counsel"; and the left pillar was called Boaz, which meant "by His Strength" (1 Kgs 7:21; 2 Chr 3:17).

Our *choices* determine whose life will be lived in our soul: God's or our own.

Psyche Soul (Notice this area is not new.)

Jer 31:12 says, "Our souls should be like a watered garden."

A double souled (not "minded") man is unstable in all his ways.

Soma Body (Again, not new)

Now, as we choose to "walk after the Spirit" and make those faith choices (see chart on page 15), our bodies are going to manifest and reflect God's Life and be "a light on top of a candlestick": Luke 11:33.

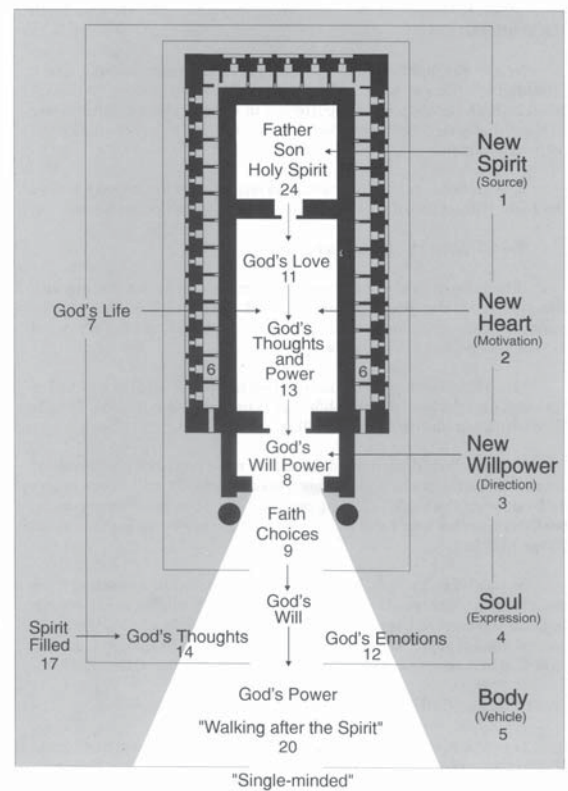

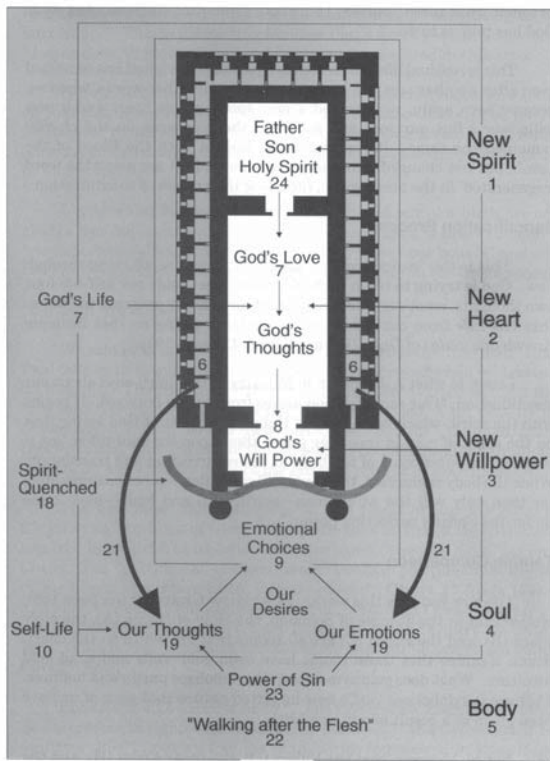

If we choose to “walk after the flesh” (see chart on page 16), making our own emotional choices, our bodies will manifest and reflect our own self life and we will be that “light hidden under a bushel.”

Hidden Chambers (Our Subconscious)

We must be careful not to stuff our junk (unresolved hurts, emotions, etc.) here. We need to continually cleanse ourselves by giving them over to Him. This is a continual process.

There were three primary items in the Inner Court: the lavers for cleansing; the altar for sacrifices; and, the “molten sea” for immersion.

Inner Court Ritual

“Taking every thought captive” (2 Cor 10:5). “Ready to revenge all disobedience” (2 Cor 10:6).

- 1) **Recognize, acknowledge, and experience** the negative emotions, desires or actions (self-life) that have just occurred. Don’t vent these feelings and don’t stuff them. Name how you are feeling. God then will expose the real root cause of your emotions: the pride, the unbelief, the fears, the insecurities, etc.
- 2) Laver (Cleansing): **Confess** your responsibility in holding on to these negative emotions. They have separated you from God and they are sin. **Repent** of them and choose to follow what God is telling you to do. **Forgive** others. Then God will also forgive your sins.

- 3) Altar of Sacrifice: **Give over** to God all that He has shown you, not only the negative emotions, but their root causes. God will then purge your sin and reconcile you to Himself.
- 4) Molten Sea: **Immerse into God's Word.** Replace the lies with the Truth. God will then cleanse and heal your soul with "the washing of the water of the Word."

* * *

Resources from The King's High Way

The Way of Agape

This study was excerpted from the famous eight hour series by Nancy Missler that was the result of her 15 years of research: What is God's Love? What does it mean to love God? Exploring these and other critical issues, Nancy shows us how we can transform the failures of human love into the victories of God's Agape Love.

Be Ye Transformed

What does it mean to truly renew our minds? What is the "Mind of Christ"? The only way we can be set free from our hidden insecurities, fears and hurts that keep us in bondage and a continual prey for the enemy, is by allowing God to constantly renew our minds.

Faith in the Night Seasons

Have you ever felt abandoned by God? Is it possible to continue to have faith in God when He allows everything in your life to fall apart? Chuck and Nancy explain why God, the Loving Father, allows these dark times.

The above resources are available as textbooks, workbooks, videos, DVDs, and audio cassette sets. Leaders Guides are also available, which make these eight-hour series perfect for small group Bible studies. For more information, including ordering and a complete list of available resources, please visit:

www.thekingshighway.org



Commentaries on MP3 CD-ROM

Chuck Missler's Expositional Commentaries are now available from Koinonia House on MP3 CD-ROM or download. Some titles are also available on DVD and audio CD. Write or call for a complete list.

Monthly News Journal

Personal UPDATE, a monthly news journal highlighting the Biblical relevance of current events, is also available by writing:

Koinonia House

P.O. Box D
Coeur d'Alene, ID
83816-0347
1-800-KHOUSE-1
www.khouse.org